

Technical Specification

MODEL : TULA35

Piezoelectric Technology CO., Ltd.

#501 Sinnae Technotown, Bonghwasan-ro 123,
Jungrang-gu, Seoul, Korea, 131 - 863

Tel. +82-2-3421-0370 Fax. +82-2-3421-0374

<http://www.piezo-tech.com>

Revision History

Date	Revision	Description
2006/12	0.1	First release
2020/4	2.0	Modified the rod diameter by $\Phi 0.8$
2021/9	3.0	

CONTENTS

MODEL NAME : TULA35

1. The full text.....	4
2. General notice.....	5
3. Characteristics of the TULA35 series motor.....	6
3-1. Mechanical characteristics.....	6
3-2. Electrical characteristics.....	7
4. Outline of TULA35-140.....	8
5. Application Information.....	9
5-1 Driving waveform.....	9
5-2 Mechanical characteristics.....	10
5-3 Position Sensors.....	11
5.4 Mobile Examples.....	12
6. Driving Circuit.....	13
6-1 Single IC solution 1.....	13
6-2 Single IC solution 2.....	13
6-3 DC-DC converter.....	14
7. Evaluation kit (PMC1804).....	15
8. Reliability test result.....	16
Endurance characteristics.....	16

PRODUCT STANDARD SPECIFICATION FOR TULA35

1. The full text

- 1) The document defines the standard specifications for the TULA35 which is to be delivered by Piezoelectric Technology co., Ltd.
- 2) Items not specified in the document, but necessary to be included shall be described in the additional specifications after discussion. This rule can be applied only if the standard product manufacturing process is not affected. Otherwise, modified items are treated as special models.
- 3) Some characteristics for electrical noise, mechanical noise, clearance noise, vibration, service life and so on should be checked after being mounted in application.
- 4) Any problem related in the present specifications should be decided by discussion between user and supplier.
- 5) Products can be partially modified for improvement, and supplier will send related information to user.
- 6) If motor is operated beyond the scope of specification or broken by user's fault, we can not guarantee the product any time.
- 7) Items related in the applicable safety standard can be decided by consultation between the user and supplier when required.

2. General notice

- 1) Please do not store or operate the motor in the atmosphere where erosive gases are present (e.g. H₂S, SO₂, NO₂ and Cl₂, etc.) and also in places where materials emit erosive gases.
- 2) Please do not store under high temperature, and low temperature, and high humidity and much dust conditions.
- 3) Please keep specifications strictly regarding voltage and capacity of the motor, and load range.
- 4) Please do not operate the motor with over-load condition. In case of indicating polarity the motor, please do not run with opposite polarity because of undesirable damage and change of characteristics on the motor.
- 5) Please do not give a great shock to the motor.
- 6) Ambient temperature might have influence on the motor. Please set the motor apart from exothermic parts such as transformer.
- 7) Please do not hold the end of wire (or FPCB) to handle the motor. If so, the characteristics of the motor may be changed or the motor may be not operated by undesirable damage.

※ **We strongly recommend to hold the part of rod with a soft material when you set up the motor in your application.**

3. Characteristics of the TULA35 series motor

3-1. Mechanical characteristics

Item	Unit	Value	Condition
Speed(No load)	mm/s	> 10	Driving voltage : 14 V Temperature : 25°C
Max-Thrust	g.f	> 10	
Holding-Force	g.f	50 ~ 80	
Stroke	mm	< 8	
Shaft length	mm	< 19	

The speed and thrust of TULA35 is affected by the mobile part feature, rod holder feature, length of rod and especially, the driving voltage. [Figure 3-1] shows the TULA meter which measures the performance of TULA35.

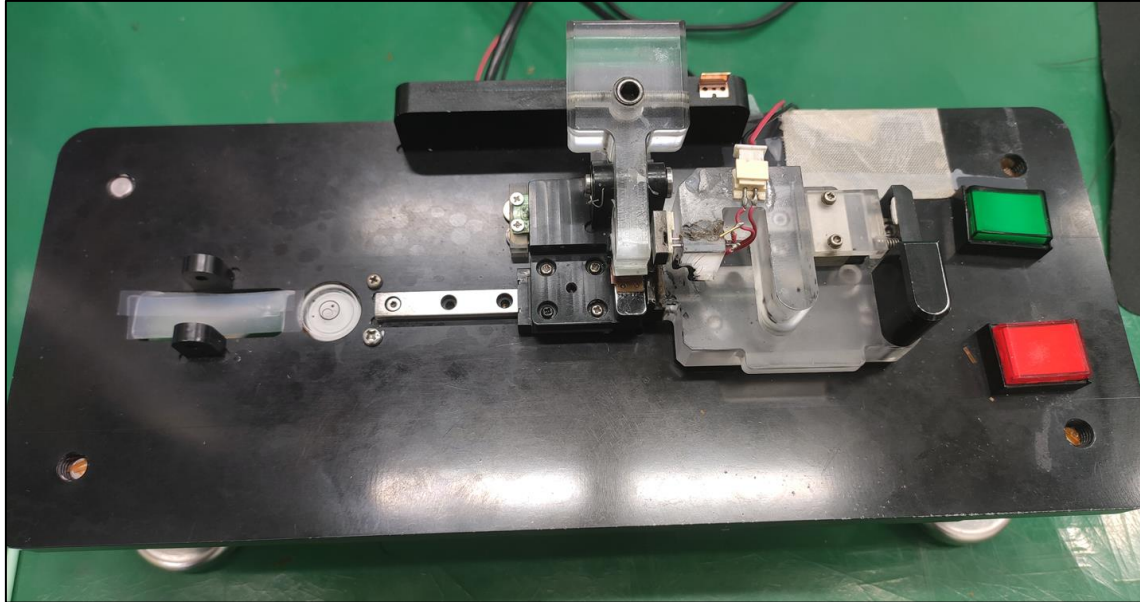

[Figure 3-1] TULA measuring equipment

3-2. Electrical characteristics

Item	Unit	Value	Condition
Driving Frequency	kHz	80 ~ 100	TULA_meter
Driving Voltage	V	14 ~ 20	
Power Consumption(14V)	mW	< 250	

There is small variance of the driving frequency because of the mobile part feature, rod holder feature and length of rod.

The power-consumption depends on the driving voltage. According to the application, the optimization must be needed.

4. Outline of TULA35-140

'140' means that rod length is 14.0 mm. The rod length can be changed by user application.

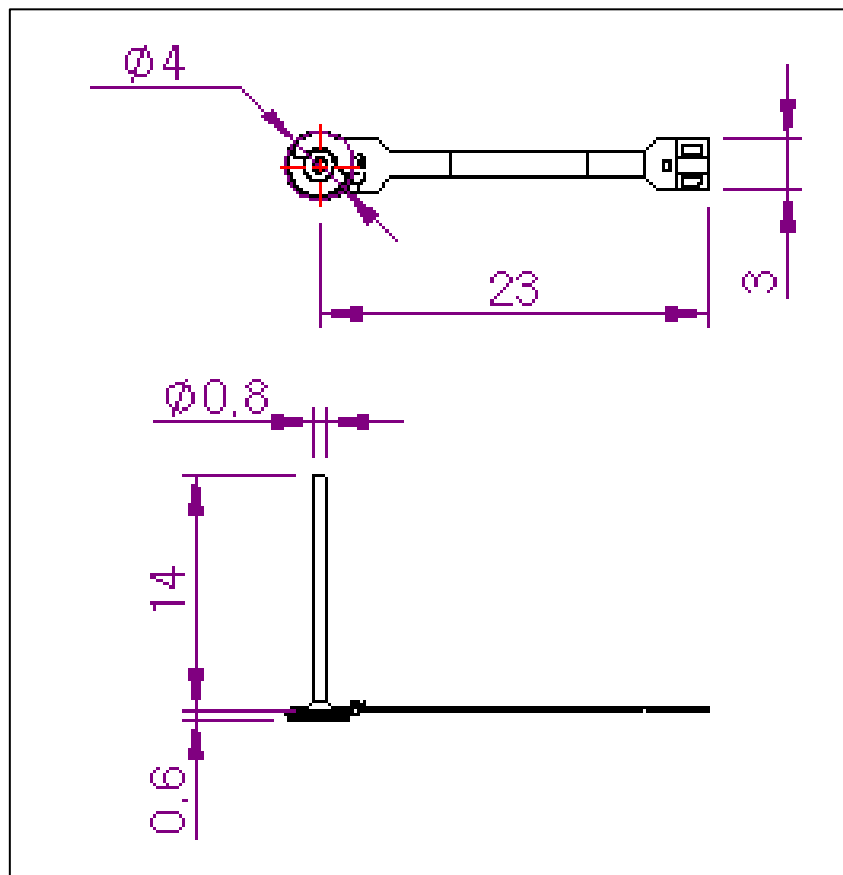
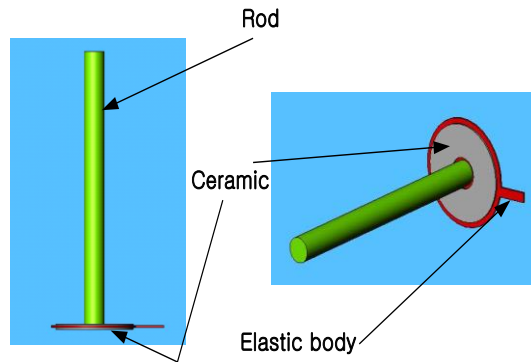

[Figure 4-1] TULA35-140

5. Application Information

5-1 Driving waveform

PWM signals to piezo motor determine the direction and speed of the mobile part.

A. Forward direction

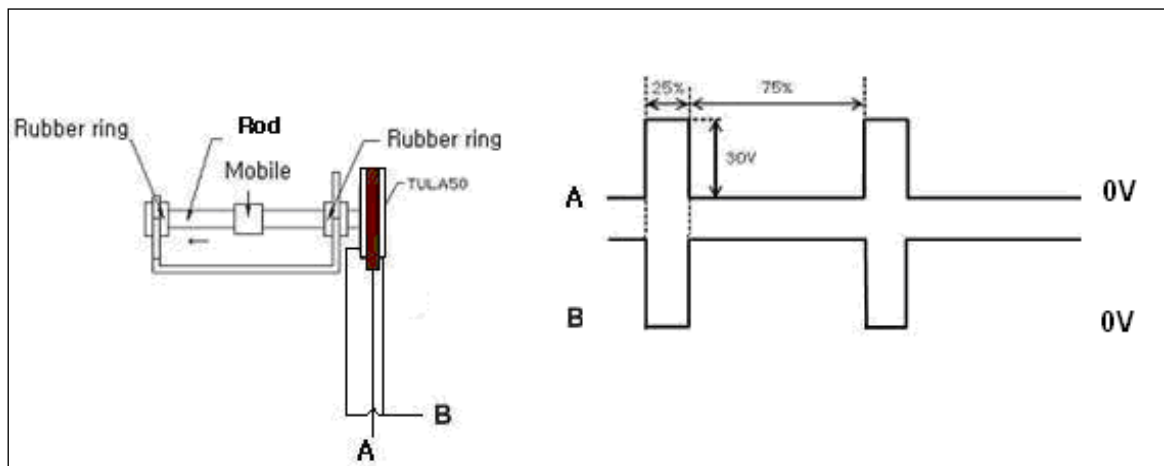

[Figure 5-1] TULA driving PWM signal

B. Reverse direction

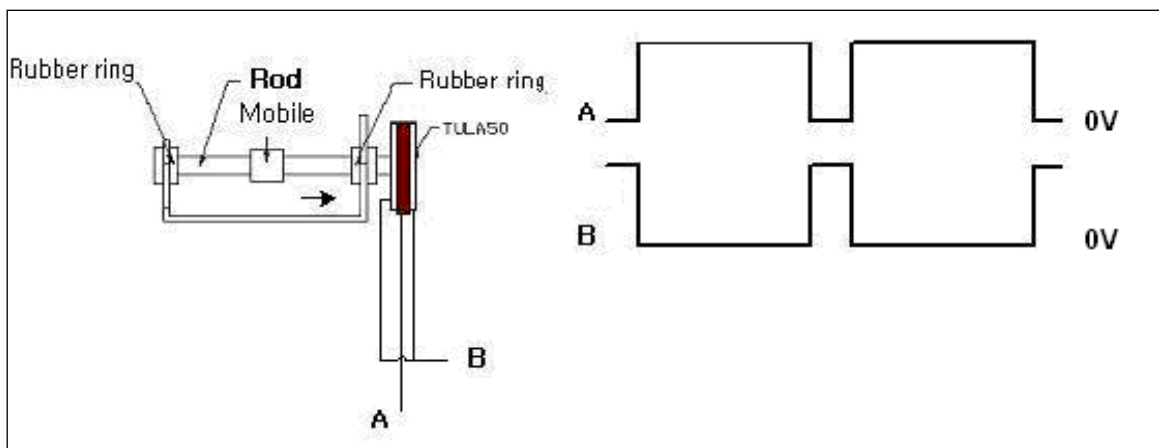

[Figure 5-2] TULA driving PWM signal

C. No operation

If the driving signals of piezo motor are in DC level or high impedance, the mobile part does not move and due to friction the mobile part keeps its position. In this case, piezo motor does not consume any power.

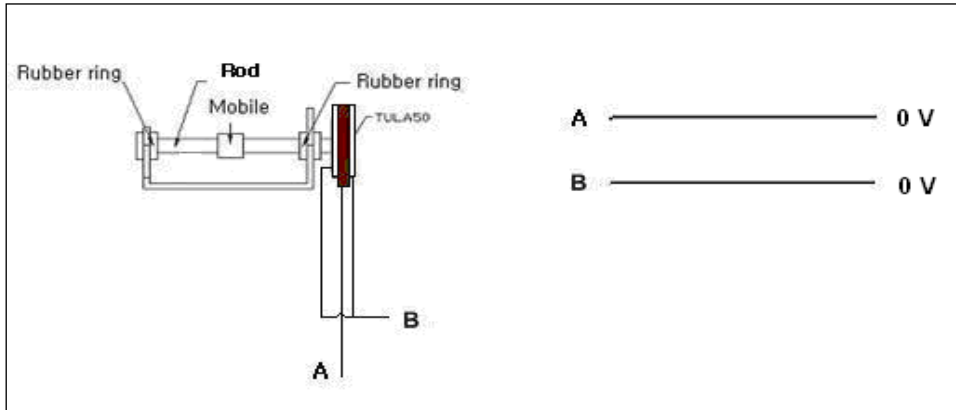

[Figure 5-3] No signal

5-2 Mechanical characteristics

In order to control the speed of piezo-motor, the duty or frequency is important factors. [Figure 5-4] shows the typical characteristics of speed and current according to the duty ratio at fixed driving frequency.

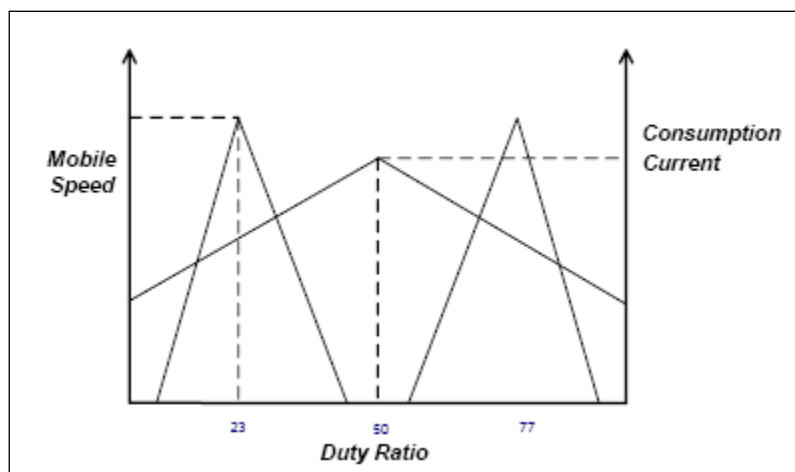

[Figure 5-4] Typical Duty vs Speed & Current

[Figure 5-5] shows the typical characteristics of the frequency versus speed. Depending on the ambient temperature, this graph will be shifted by several kHz

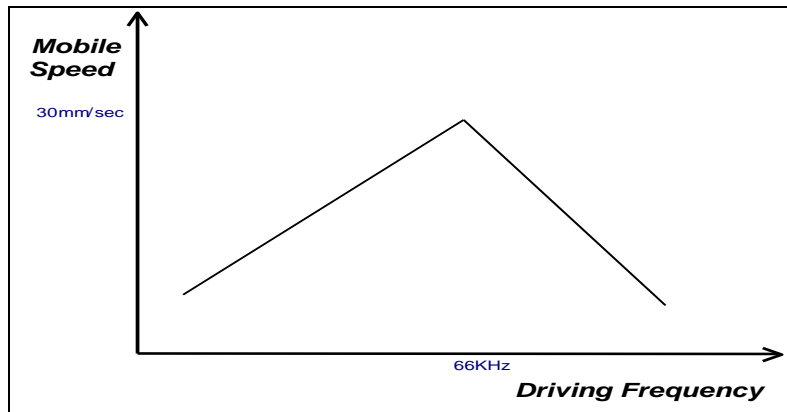

[Figure 5-5] General frequency characteristics

[Figure 5-6] shows the typical compressive force versus thrust and speed. In order to get more thrust, it needs more compressive force to some extent. Inversely, for high speed, then lowers a compressive force of mobile part.

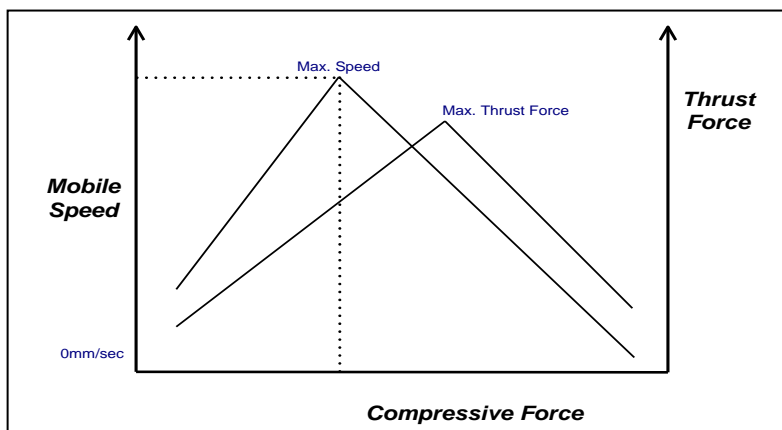

[Figure 5-6] Compressive force vs. speed & thrust

5-3 Position Sensors

Position sensor or encoder must be needed for close-loop precision control. MR (Magnetic Resistive) sensor, hall sensor, PR (photo reflector) or encoder can be used to get the position of mobile part. The accuracy and resolution depends on sensor or encoder used.

5.4 Mobile Examples

[Figure 5-7] shows the one-body mobile example. It has a small form-factor so it is very useful to design the slim and compact device.

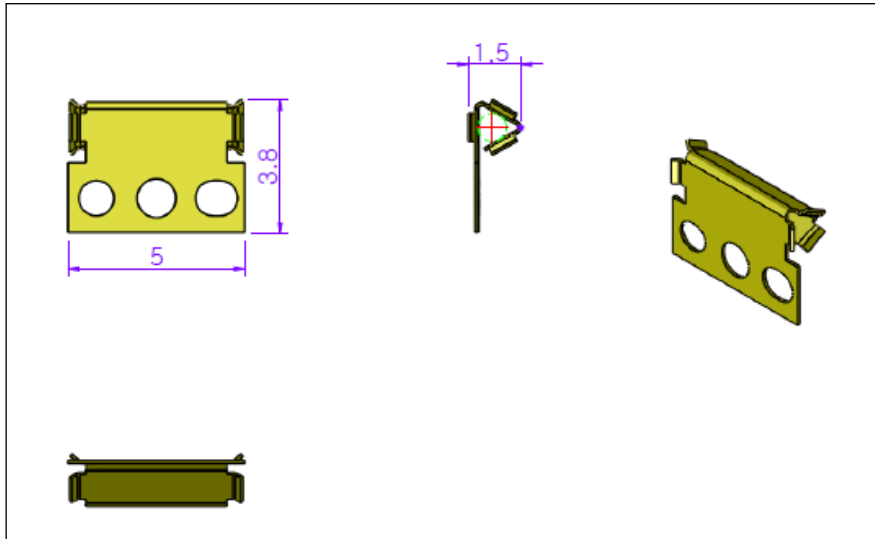

[Figure 5-7] Dimension of a standard mobile-part

6. Driving Circuit

6-1 Single IC solution 1

LT3572 is 2 channel single chip solution for TULA. For more information, please refer to the technical data-sheet of LT3572.

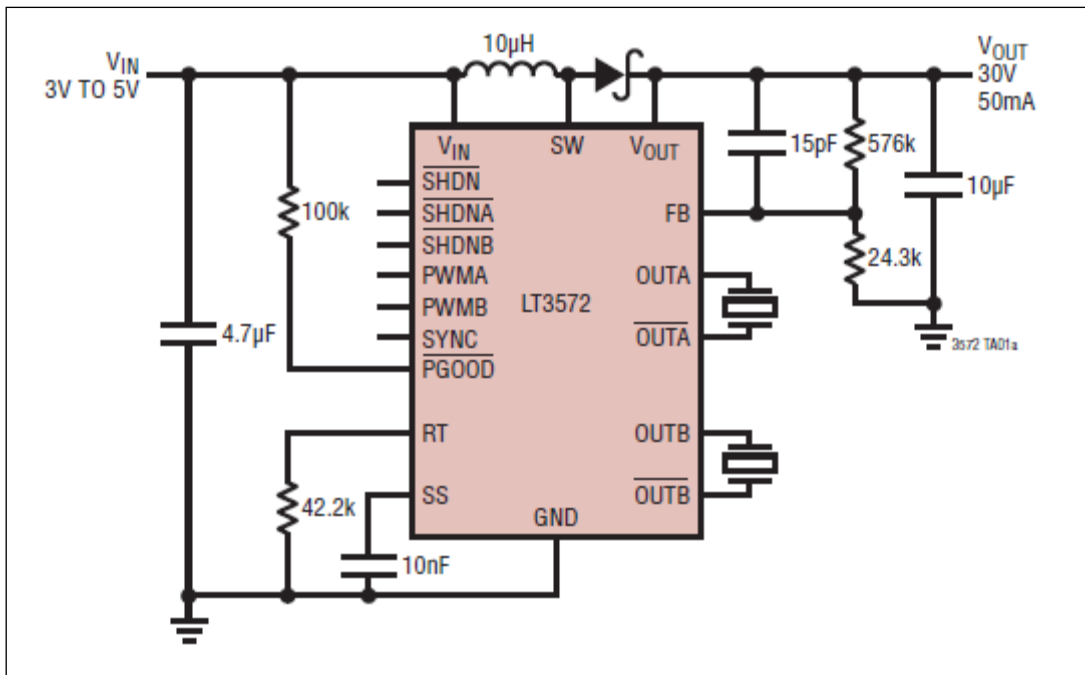

[Figure 6-1] LT3572 typical application

6-2 Single IC solution 2

NJW4813/4814 from "JRC" is single chip solution. NJW4814 is for 2 channels and NJW4813 is for single channel. For more information, please refer to the technical data-sheet of NJW4814 or NJW4813.

7. Evaluation kit (PMC1804)

To understand TULA-operation and develop user's application easily, "PMC-1804" is available. The driving frequency, voltage and duty ratio can be adjusted. For more information, please refer to "PMC-1804 operation manual".

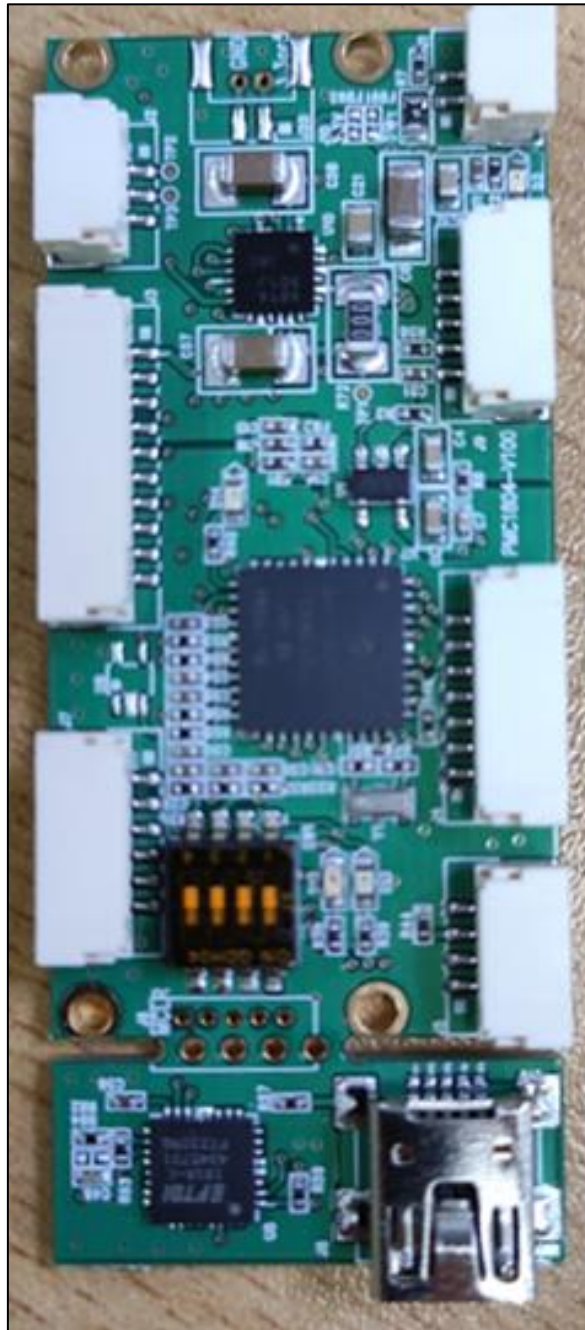

[Figure 7-1] PMC1804

8. Reliability

Endurance characteristics

Approximately 80% of initial performance is guaranteed after 1,000,000 cycles movement with following conditions.

Test conditions: 2 mm stroke at the center of rod,
 Max. speed movement.
 'Test Jig' provided by P.T Company.